

STICKER 50 TBDE

Poluautomatska mašina za lepljenje kutija



Tehničke karakteristike

Transportna traka	Nastro L=50 mm
Brzina ulaganja	22 mt/1'
N. 2 traka PPL/PVC	STD
Širina trake:	50 mm - 50 W=135 mm / 50/75 mm - 50 W=160
Napajanje	230 V. 1-Ph -50HZ +T
Instalirana snaga	0,4 kW

Karakteristike proizvoda

Dužina x Širina x Visina (LxWxH) min.	150x135x110 mm - 50 TBDE W=135 MM
Dužina x Širina x Visina (LxWxH) min.	150x160x110 mm - 50 TBDE W=160 MM
Dužina x Širina x Visina (LxWxH) max.	∞x500x500
Težina kutije:	Max. 50 Kg

www.masinezapakovanje.com



STICKER 50 TBDE

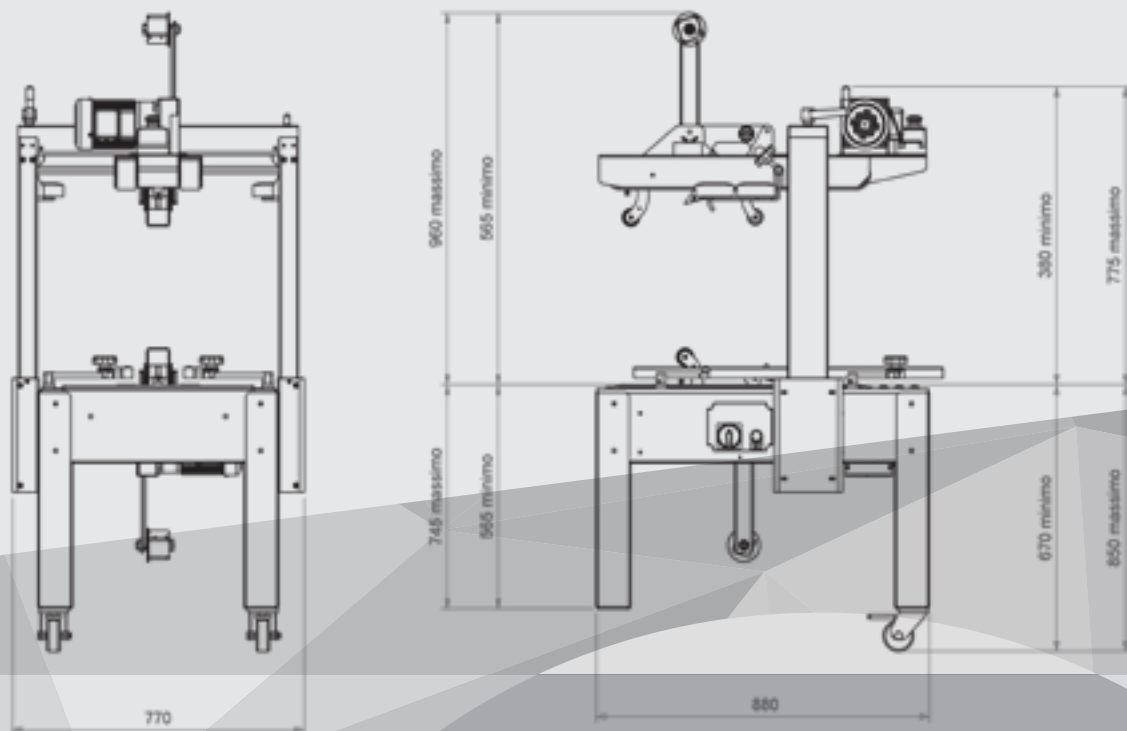

Gausi doo
Gundulićev venac 37
11000 Beograd
Srbija

Tel. +381 3392 706
Tax +381 3392 731
info@gausi.com