

NOXON

EKKO

POLUAUTOMATSKA MAŠINA ZA STREČOVANJE PALETA SA OBTNOM PLOČOM
SEMI-AUTOMATIC TURNTABLE, FOR PALLET WRAPPING WITH STRETCH FILM

ENG/SRB



*Simple, sturdy and
reliable*

*Jednostavna,
robusna i poudana*

**SEMI-AUTOMATIC TURNTABLE, FOR PALLET WRAPPING WITH STRETCH FILM
POLUAUTOMATSKA MAŠINA ZA STREČOVANJE PALETA SA OBRTNOM PLOČOM**



**„X3“-Kontrolni panel
“X3” CONTROL/
Korisnički
interfejs - grafički tasteri
sa membranom
Operator Interface with
graphic membrane
keypad and
2.23” OLED DISPLAY**

“X3” PREGLED KOMANDI / SPECIFICATIONS CONTROL/

- Brzina nosača folije gore-dole**
Upward-downward carriage speed
- Tenzija omotavanja na dnu i vrhu palete**
Top and bottom reinforcement wraps
- Tenzija zategnuti folije / Film tension**
- Brzina okretanja obrtne ploče / Table rotation speed**
- Zaustavljanje nosača folije na ergonomiku visinu**
Ergonomic carriage stop at the end of the cycle
- Ciklus gore-dole / Upward-downward cycle**
- Ciklus samo gore / Only upward cycle**
- Ciklus omotavanja na vrhu / Top sheet cycle**
- Ručni ciklus / Manual cycle**
- Ciklus samoučenja / Self learning cycle**
- Fotočelija za visinu palete i odloženi start**
Altimeter and photocell delay
- Učitavanje 6 različitih programa / 6 recordable programs**

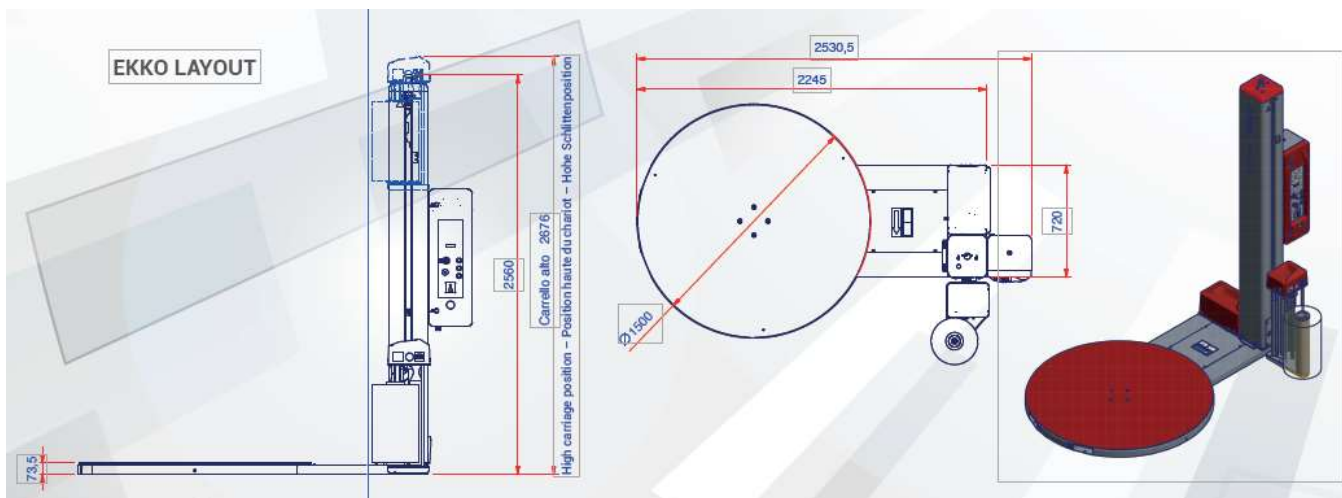



302
NOSAČ FOLIJE SA MEHANIČKOM KOČNICOM ZA PODEŠAVAJE ZATEGNUTOSTI FOLIJE.

Podešavanje zategnutosti folije kojom se obavija paleta opremljen je jednostavnim mehanizmom koji omogućava brzo uključivanje/isključivanje ove funkcije.

FILM CARRIAGE WITH MANUALLY ADJUSTABLE MECHANICAL BRAKE.

The "Film's Tension" adjustment allows to set the tension with which the film is applied to the product. The carriage is equipped with a quick engagement and disengagement device to facilitate the hooking of the film on the product.



310
Nosač folije sa elektromagnetnom kočnicom na povratnom valjku. Tenzija zategnutosti folije se podešava preko panela. Kočnica se lako aktivira nakon pokretanja ciklusa.

Film carriage with electromagnetic brake on return roller. Stretch tension adjustable from control panel. Brake coupling after cycle start for easy filmhookingtopalletbase.



312
Nosač folije opremljen fiksnim pre-sreč sistemom 250%. Sila zategnutosti kontrolisana preko merne ćelije i podešava se preko panela

The carriage is fitted with a pre-stretching system fixed at 250%, Force to the load controlled by load cell and adjustable from control panel.

TECHNICAL FEATURES / TEHNIČKE KARAKTERISTIKE

MACHINE / MODEL	EKKO 302	EKKO 310	EKKO 312
Carriage type / Tip nosača folije	Mechanical brake Mehanička kočnica	Electromagnetic power brake/ Elektromagnetna kočnica	Power pre-stretch motorized / Motorizovani pre-streč
Film stretch / Zatezanje folije	Manual adjustment Ručno podešavanje	Adjustable from panel Podešavanje preko panela	Potentiometer / Potencijometar
Pre-stretch / Pre-streč	No	No	250%
Power supply voltage / Napajanje	(VAC) 230V 1 PH(±10%) 50/60 Hz		
Installed power / Instalirana snaga	1,2 kW	1,5 kW	1,9 kW
Carriage up-down speed / Brzina nosača folije	1,4÷4 m/min		
Table rotation speed / Brzina rotiranja obrtne ploče	5÷12 rpm	5÷12 rpm	5÷12 rpm
Plate diameter / Prečnik obrtne ploče	Ø 1500 STD (59") - Ø 1650 OPT (65")		
Plate capacity / Nosivost obrtne ploče	2000kg/ 4409lb STD		
Phase stopping point / Fazno zaustavljanje	STD		
Progressive start-up / Progresivan start	STD		
Photocell delay / Fotoćelija za odloženi start	STD		
Height detection photocell / Fotoćelija za detekciju visine	STD		
Front and rear forklift capability / Omogućen prilaz za premeštanje viliuškarom	STD		
PRODUCT CHARACTERISTICS / KARAKTERISTIKE PAKOVANJA			
Min product dimensions / Minimalne dimenzije pakovanja	LxWxH 500 x 500 x 500 (mm) / 20 x 20 x 20 (")		
Max product dimensions / Maksimalne dimenzije pakovanja	LxWxH 800x1200x2200 (mm) STD / 31 x 47 x 87 (") 1000X1200X2400 (mm) OPT 39 x 47 x 94 (")		
FILM FEATURES / KARAKTERISTIKE FOLIJE			
Max. External diameter / Max. spoljni prečnik.	300 mm / 12"		
Reel height / Širina folije	500 mm / 20"		
Film thickness / Debljina folije	17÷35 µm		
Internal diameter / Unutrašnji prečnik hilzne	76 mm / 3"		
Max spool weight / Max. težina rolne	20 kg / 45 lb		

EKKO

POLUAUTOMATSKA MAŠINA ZA STREČOVANJE SA OBRTNOM PLOČOM

Ekko predstavlja prvu Noxonovu investiciju u vertikalne mašine za strečovanje sa obrtnom pločom.

Ekko serija je dizajnirana kombinovanjem najboljih tehnologija za pakovanja sa inovativnim i osnovnim dizajnom, dok istovremeno ispunjava najstrože međunarodne bezbednosne standarde. Posebna pažnja je posvećena podešavanju faza ubrzanja i usporavanja obrtne ploče kako bi se osigurala maksimalna sigurnost pri rukovanju nestabilnim teretima. Ove karakteristike, zajedno sa novom linijom nosača folija i „X3“ kontrolnim panelom, čine EKKO jednostavnim, robusnim i pouzdanim

SEMI-AUTOMATIC TURNTABLE FOR PALLET WRAPPING WITH STRETCH FILM

Ekko represents Noxon's first investment in vertical turntable wrappers. Ekko has been designed by combining the best packaging technologies with an innovative and essential design, while also meeting the strictest international safety standards. Particular attention has been paid to adjusting the acceleration and deceleration phases of the turntable to ensure maximum safety when handling unstable loads. These features, together with the new carriage line and the "X3" control, make the EKKO simple, robust and reliable.

NOXON

Gausi pak
Beograd, Gundulićev venac 37
[Tel: +381 11 3392731, 3392720](tel:+381113392731)
e-mail: info@gausi.com
WWW.Masinezapakovanje.com

3470300346 - 05/2022
ENG/FRA/DEU