

# NOXON

SRB/ENG

## FREESBY

*POLUAUTOMATSKA MAŠINA ZA STREČOVANJE PALETA SA OBRTNOM PLOČOM*

*SEMI-AUTOMATIC TURNTABLE FOR PALLET WRAPPING WITH STRETCH FILM*



[www.noxon.it](http://www.noxon.it)



# KONTROLNI PANEL / CONTROL PANEL

Kontrolni paneli X4 i X5 su dva inovativna kontrolna panela laka za upotrebu, korisna za programiranje i praćenje svih mašinskih ciklusa, sa mogućnošću izmene tenzije povlačenja folije i prilagođavanja programa za obmotavanje paleta.

The X4 control and the X5 control, are two user-friendly and innovative panels, useful for programming and monitoring all machine cycles, with the possibility of modifying film pull levels and customising wrapping programmes.



POČETNI EKRAN  
HOMEPAGE VIEW

## X4 PANEL / X4 CONTROL

**3,5" kontrolni panel+ JOG potencijometar za izbor programa / 3.5" colour display + JOG to select programmes**

**10 podešenih programa / 10 pre-set winding programmes**

**Mogućnost podešavanja tenzije odmotavanja folije / Possibility of film pull modification during the winding cycle**

**Ciklus u kojem mašina pamti korake / Self-learning cycle / Ciclo de autoaprendizaje**

## X5 PANEL / X5 CONTROL

● **7" ekran osetljiv na dodir / 7" touch screen colour display**

● **Novi dizajn i novo korisničko iskustvo (UX) / New design and user experience (UX)**

● **16 podešenih programa i 8 podešenih aplikacija / 16 winding programmes and 8 pre-set applications**

● **Mogućnost podešavanja i modifikovanja svih parametara / Possibility of customising and modifying winding parameters**

● **Režim tempomata (automatsko podešavanje brzine namotavanja) / Cruise Control mode (automatic winding speed adjustment)**

●



PREGLED TEMPOMATA  
CRUISE CONTROL VIEW



**N connect je sistem za nadzor, kontrolu, obradu i skladištenje podataka u realnom vremenu sa instaliranih mašina N connect is a system for the supervision, control, processing and storage of real-time data from installed machines.**

### N connect omogućava:

- Uštedite troškove kroz optimizaciju produktivnosti i preventivno održavanje
- Pratite performanse i statističke podatke o upotrebi mašina
- Proverite status mašine da biste brzo identifikovali probleme

### Nconnect allows you to:

- Cost savings through productivity optimisation and preventive maintenance
- Monitoring performance and machine utilisation data
- Check the condition of the machine to be ready to quickly identify any problems

310



**NOSAČ FOLIJE 310:** Nosač folije sa elektromagnetnom kočnicom na povratnom valjku. Tenzija zategnutosti folije se podešava preko panela. Kočnica se lako aktivira nakon pokretanja ciklusa.

**CARRIAGE 310:** equipped with **film stretching device by electromagnetic brake** adjustable from control panel. Brake coupling after cycle start for easy film hooking to pallet base.

312



**NOSAČ FOLIJE 312:** opremljen motorom sa fiksnim pre-streč istezanjem od 250%. Odnos pred istezanja se može prilagoditi i proširiti opcijama prethodnog istezanja od 150%, 200% ili 300%. Zatezanje filma se vrši preko ćelije za opterećenje, koja se može podesiti preko kontrolnog panela.

**CARRIAGE 312:** is equipped with a **single motor pre-stretch with fixed ratio of 250%**. The pre-stretch ratio can be customised and expanded with pre-stretch options of 150%, 200% or 300%. Film tensioning is via a load cell, which can be adjusted through the control panel.

314



**NOSAČ FOLIJE 314:** karakterišu dva nezavisna motora koji omogućavaju promenljivo predistezanje filma od 150% do 400%. Pre-streč istezanje i tenzija filma mogu se podesiti preko kontrolnog panela putem ćelije za opterećenje.

**CARRIAGE 314:** features **two independent motors that allow variable film pre-stretching from 150% to 400%**. Both pre-stretching and film tensioning can be adjusted via the control panel through a load cell.



# FREESBY

*POLUAUTOMATSKA MAŠINA ZA STREČOVANJE PALETA SA OBRTNOM PLOČOM*  
*SEMI-AUTOMATIC TURNTABLE FOR PALLET WRAPPING WITH STRETCH FILM*

SCAN FOR MORE INFO



## FREESBY LAYOUT

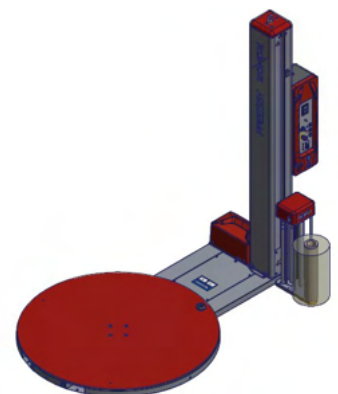
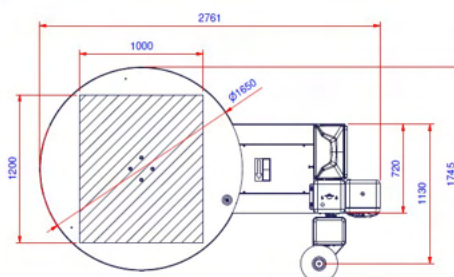
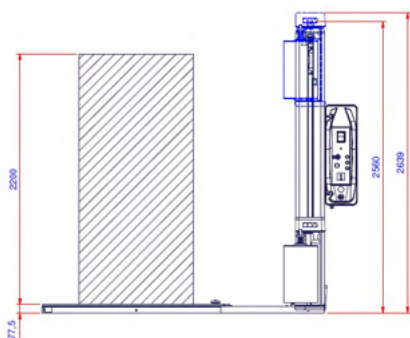

## FRESBY FOCUS POINTS

Poluautomatska rotaciona ploča je dizajnirana sa posebnom pažnjom na jednostavnost upotrebe zahvaljujući novim multifunkcionalnim panelima. Karakteristike obrtne ploče su dizajnirane za stabilizaciju lakih i nepravilnih opterećenja.

Semi-automatic turntable is designed with a focus on ease of use thanks to new user-friendly multifunctional panels and to the features of the turntable designed for stabilising light and irregular loads.

**MAKSIMALNA STABILIZACIJA PALETE**  
MAXIMUM STABILISATION OF THE PALLET

**JEDNOSTAVNO RUKOVANJE ZAHVALJUJUĆI KONTROLNIM PANELIMA X4 i X5**  
EASE OF USE THANKS TO THE LATEST X4 AND X5 CONTROL PANELS

**MAKSIMALNA SVESTRANOST UZ MOGUĆNOST SAVRŠENOG PRILAGOĐAVANJA BILO KOM ZAHTEVU ZA PAKOVANJA.**  
MAXIMUM VERSATILITY WITH THE ABILITY TO ADAPT PERFECTLY TO ANY PACKAGING REQUIREMENT.

## TEHNIČKE KARAKTERISTIKE / TECHNICAL FEATURES

	FRESBY X4 310	FRESBY X4 312	FRESBY X5 312	FRESBY X5 314
Nosač folije / Carriage type	Elektromagnetna kočnica / Electromagnetic power brake	Motorizovani pre-streč / Power pre-stretch motorized	Motorizovani pre-streč / Power pre-stretch motorized	2 varijabilna motora za pre-streč / 2 variable pre-stretch motors
Zatezanje folije / Film stretch	Ručno podešavanje / Manual adjustment	Podešavanje preko panela / Adjustable from panel	Podešavanje preko panela / Adjustable from panel	Podešavanje preko panela / Adjustable from panel
Pre-streč / Pre-stretch	Na	250%	250%	150÷400%
Napajanje / Power supply voltage	230V 1 PH(±10%) 50/60 Hz			
Instalisana snaga / Installed power	1,5 kW	1,9 kW	1,9 kW	2,3 kW
Brzina nosača gore/dole / Carriage up-down speed	1,4÷4 m/min			
Brzina rotacije obrtne ploče / Table rotation speed	5÷12 rpm			
Dimezija obrtne ploče / Plate diameter	Ø 1650 mm STD - Ø 1800 mm Opt.			
Nosivost obrtne ploče / Plate capacity	2000kg			
Sinhronizovano zaustavljanje / Synchronised stop	STD			
Progresivan start / Progressive start-up	STD			
Podešavanje fotočelije / Photocell delay	STD			
Detekcija visine fotočelijom / Height detection photocell	STD			
Omogućeno premeštanje viljuškaram / Front and rear forklift capability	STD			

# FREESBY T3

**POLUAUTOMATSKA MAŠINA ZA STREČOVANJE SA T ULAZOM ZA PALETNI VILJUŠKAR**  
**SEMI-AUTOMATIC TURNTABLE FOR PALLET WRAPPING WITH STRETCH FILM**

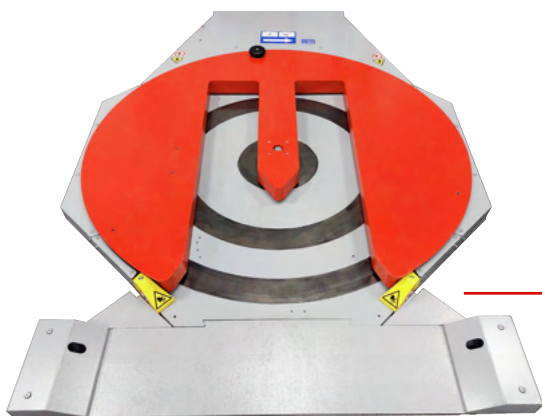

**VERZIJA FREESBY T3**  
**Transpaleto obrtna ploča za ulaz paletnog viljuškara**  
**FREESBY T3 VERSION**  
*With transpallet plate for manual loading without forklift*

SCAN FOR MORE INFO



## FREESBY T3 LAYOUT

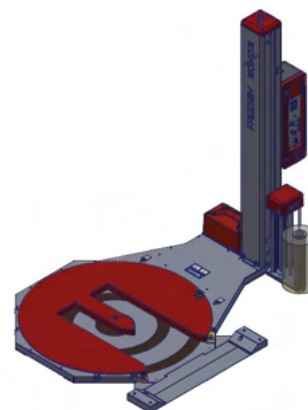
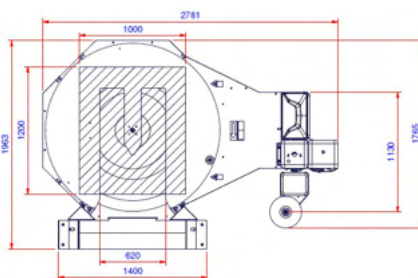
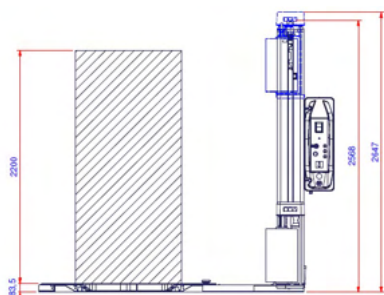

## FREESBY T3 FOCUS POINTS

*Freesby T3 poluautomatska mašina sa transpalet obrtnom pločom za ulaz paletnog viljuškara, dizajnirana je da omogućava prenošenje mašine viljuškarom sa tri različite strane .*

*The Freesby semi-automatic turntable is designed with the T3 base, designed to load the turntable with forklifts, with the possibility of changing the loading side by choosing three different configurations according to requirements.*

**IDEALNA ZA ULAZ PALETNOG VILJUŠKARA SA SPECIJALNO DIZAJNIRANOM OBRTNOM PLOČOM U T OBLIKU**  
LOADING WITH HAND PALLET TRUCK THANKS TO THE SPECIALLY DESIGNED SHAPED PLATE

**ZAHVALJUJUĆI FLEKSIBILNOSTI NOVOG DIZAJNA OBRTNE PLOČE MAŠINA MOŽE BITI POSTAVLJENA SA 3 RAZLIČITE STRANE**  
FLEXIBILITY THANKS TO THE NEW BASE, IT CAN BE INSTALLED IN 3 DIFFERENT LOADING LINES

**BEZBEDNOST I POUZDANOST JE OMOGUĆENA ZAHVALJUJUĆI INTEGRISANOM SIGURNOSNOM SISTEMU I SPECIJALNOM SISTEMU ROTACIJE OBRTNE PLOČE**  
SAFETY AND RELIABILITY THANKS TO THE INTEGRATED SAFETY SYSTEM AND SPECIAL PLATE ROTATION SYSTEM

## TEHNIČKE KARAKTERISTIKE / TECHNICAL FEATURES

	FREESBY T3 X4 310	FREESBY T3 X4 312	FREESBY T3 X5 312	FREESBY T3 X5 314
Tipo carrello / Carriage type	Freno elettromagnetico / Electromagnetic power brake	Prestiro fisso ad un motore / Power pre-stretch motorized	Prestiro fisso ad un motore / Power pre-stretch motorized	Prestiro variabile a 2 motori / 2 variable pre-stretch motors
Tiro film / Film stretch	Regolabile da pannello / Manual adjustment	Regolabile da pannello / Adjustable from panel	Regolabile da pannello / Adjustable from panel	Regolabile da pannello / Adjustable from panel
Pre-stiro / Pre-stretch	N/A	250%	250%	150÷400%
Tensione alimentazione / Power supply voltage	230V 1 PH(±10%) 50/60 Hz			
Potenza installata / Installed power	1,5 kW	1,9 kW	1,9 kW	2,3 kW
Velocità salita-discesa carrello / Carriage up-down speed	1,4÷4 m/min			
Velocità rotazione tavola / Table rotation speed	5÷12 rpm			
Diametro piatto / Plate diameter	Ø 1650 mm STD - Ø 1800 mm Opt.			
Portata piatto / Plate capacity	1500kg			
Arresto in fase / Phase stopping point	STD			
Avvio progressivo / Progressive start-up	STD			
Ritardo fotocellula / Photocell delay	STD			
Fotocellula lettura altezza / Height detection photocell	STD			
Inforcabilità anteriore e posteriore / Front and rear forklift capability	Posteriore			



# FREESBY LP

**POLUAUTOMATSKA MAŠINA ZA STREČOVANJE PALETA SA OBRTNOM PLOČOM I LP (LOW PROFILE) SISTEMOM NAVOŽENJA PALETA PALETNIM VILJUŠKAROM I VILJUŠKAROM**  
**SEMI-AUTOMATIC TURNTABLE FOR PALLET WRAPPING WITH STRETCH FILM**



*LP baza omogućava pristup sa svih strana putem paletnih viljuškara i viljuškara, izbegavajući slučajne udare.*  
*The LP base allows access from all sides by pallet trucks and forklifts, avoiding accidental impacts.*

SCAN FOR MORE INFO



## FREESBY LP LAYOUT

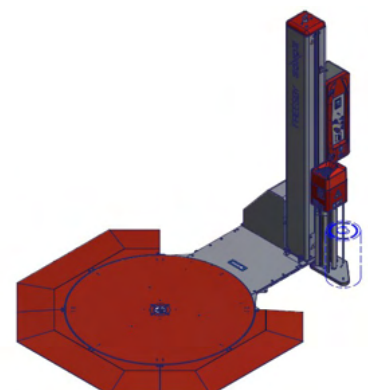
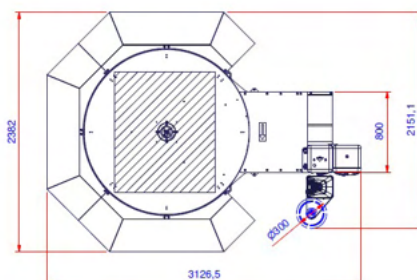
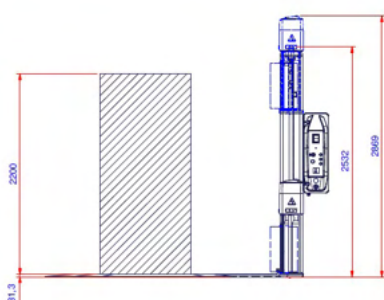



## FREESBY LP FOCUS POINTS

*Freesby LP sa bazom koja omogućava pristup sa svih strana pomoću paletnih viljuškara i viljuškara. Visina osnove takođe vam omogućava da izbegnete slučajne udarce viljuškama, što olakšava utovar.*

*The Freesby LP turntable with base which allows access from all sides by pallet trucks and forklifts. The height of the base also prevents accidental collisions with the forks, facilitating loading.*

**FLEKSIBILNOST POSTAVLJANJA PALETA ZAHVALJUJUĆI BAZI KOJA OMogućAVA PRISTUP SA SVIH STRANA**

*FLEXIBILITY OF LOADING THANKS TO THE BASE THAT ALLOWS ACCESS FROM ALL SIDES*

**SMANJENE DIMENZIJE ZAHVALJUJUĆI RAMPAMA KOJE ŠTEDE PROSTOR**

*SMALL DIMENSIONS THANKS TO SPACE-SAVING RAMPS*

**LAKO POSTAVLJANJE PALETA ZAHVALJUĆI MALOJ VISINI RAMPE (30 MM)**

*EASE OF LOADING THANKS TO THE LOW THICKNESS OF THE BASE (30 MM)*

## TEHNIČKE KARAKTERISTIKE / TECHNICAL FEATURES

	FREESBY LP X4 310	FREESBY LP X4 312	FREESBY LP X5 314
Tipo carrello / Carriage type	Freno elettromagnetico / Electromagnetic power brake	Prestiro fisso ad un motore / Power pre-stretch motorized	Prestiro variabile a 2 motori / 2 variable pre-stretch motors s
Tiro film / Film stretch	Regolabile da pannello Manual adjustment	Regolabile da pannello Adjustable from panel	Regolabile da pannello Adjustable from panel
Pre-stiro / Pre-stretch	N/A	250%	150÷400%
Tensione alimentazione / Power supply voltage	230V 1 PH(±10%) 50/60 Hz		
Potenza installata / Installed power	1,5 kW	1,9 kW	2,3 kW
Velocità salita-discesa carrello / Carriage up-down speed	1,4÷4 m/min		
Velocità rotazione tavola / Table rotation speed	5÷12 rpm		
Diametro piatto / Plate diameter	Ø 1650 mm STD		
Portata piatto / Plate capacity	1200kg		
Arresto in fase / Phase stopping point	STD		
Avvio progressivo / Progressive start-up	STD		
Ritardo fotocellula / Photocell delay	STD		
Fotocellula lettura altezza / Height detection photocell	STD		
Inforcabilità anteriore e posteriore / Front and rear forklift capability	STD		

# FREESBY MAX

*POLUAUTOMATSKA MAŠINA ZA OBMOTAVANJE PALETA STREČ FOLIJOM*  
*SEMI-AUTOMATIC TURNTABLE FOR PALLET WRAPPING WITH STRETCH FILM*

SCAN FOR MORE INFO



## FREESBY MAX LAYOUT

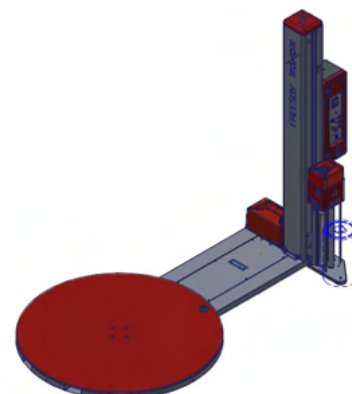
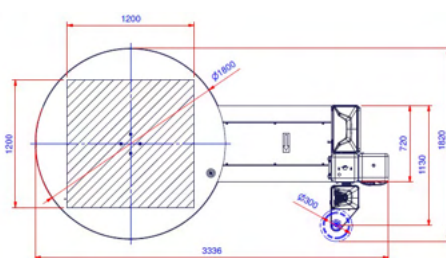
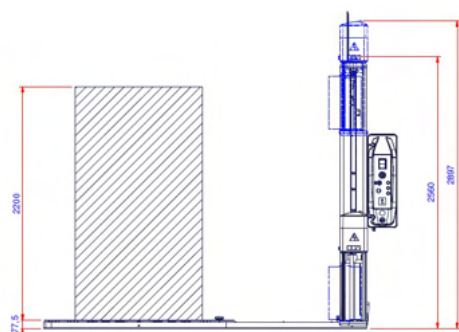

## FRESBY MAX FOCUS POINTS

*Freesby MAX je na čelu svoje pouzdanosti i produktivnosti, dizajniran je sa posebnom pažnjom za obmotavanje velikih paleta, zahvaljujući povećanom prečniku obrtne ploče.*

*The Freesby MAX is at the forefront of reliability and productivity and is designed with a special focus on wrapping large pallets, thanks to the increased plate diameter.*

**MAKSIMALNA STABILNOST PALETA**  
MAXIMUM STABILISATION OF THE PALLET

**IDEALNA ZA PALETE VELIKIH DIMENZIJA**  
IDEAL FOR LARGE SIZE PALLETS

## TEHNIČKE KARAKTERISTIKE / TECHNICAL FEATURES

	FRESBY MAX X4 310	FRESBY MAX X4 312	FRESBY TMAX X5 312	FRESBY MAX X5 314
Tipo carrello / Carriage type	Freno elettromagnetico / Electromagnetic power brake	Prestiro fisso ad un motore / Power pre-stretch motorized	Prestiro fisso ad un motore / Power pre-stretch motorized	Prestiro variabile a 2 motori / 2 variable pre-stretch motors
Tiro film / Film stretch	Regolabile da pannello Manual adjustment	Regolabile da pannello Adjustable from panel	Regolabile da pannello Adjustable from panel	Regolabile da pannello Adjustable from panel
Pre-stiro / Pre-stretch	Na	250%	250%	150÷400%
Tensione alimentazione / Power supply voltage	230V 1 PH(±10%) 50/60 Hz			
Potenza installata / Installed power	1,5 kW	1,9 kW	1,9 kW	2,3 kW
Velocità salita-discesa carrello / Carriage up-down speed	1,4÷4 m/min			
Velocità rotazione tavola / Table rotation speed	5÷12 rpm			
Diametro piatto / Plate diameter	Ø 1800 mm STD - Ø 2200 - Ø 2400 mm			
Portata piatto / Plate capacity	2000kg			
Arresto in fase / Phase stopping point	STD			
Avvio progressivo / Progressive start-up	STD			
Ritardo fotocellula / Photocell delay	STD			
Fotocellula lettura altezza / Height detection photocell	STD			
Inforcabilità anteriore e posteriore Front and rear forklift capability	STD			

# FREESBY

## **POLUAUTOMATSKA MAŠINA SA ROTACIONOM PLOČOM ZA OBMOTAVANJE PALETA STREČ FOLIJOM**

*Nova generacija vertikalnih mašina sa rotirajućim pločama koji redefinišu standarde pouzdanosti i produktivnosti u industriji. Predstavljamo novi Freesby!*

*Freesby je na čelu svoje pouzdanosti i produktivnosti, dizajniran je sa posebnom pažnjom na jednostavnu upotrebu zahvaljujući novim multifunkcionalnim panelima prilagođenim korisnicima. Obrtna ploča JE dizajnirana za stabilizaciju lakih i nepravilnih paleta, sa mogućnošću daljinskog praćenja funkcija zahvaljujući sistemu N connect. Freesby ima dva inovatna kontrolna panela X4 i X5 korisna za programiranje i praćenje svih mašinskih ciklusa, sa mogućnošću modifikacije tenzije povlačenja filma i prilagođavanja programa za obmotavanje paleta*

## **SEMI-AUTOMATIC TURNTABLE STRETCH FILM PALLET WRAPPER**

*The new generation of turntable stretch wrapping machines that is redefining the standards of reliability and productivity in the industry. We introduce you to the new Freesby!*

*The Freesby is at the forefront of reliability and productivity and is designed with a focus on ease of use thanks to new user-friendly multifunctional panels and to the features of the turntable designed for stabilising light and irregular loads, with the possibility of remote monitoring of functions thanks to the N connect system.*

*The Freesby has two user-friendly and innovative control panels (X4 and X5 controls), useful for programming and monitoring all machine cycles, with the possibility of modifying film pull levels and customising wrapping programmes.*

# NOXON

*Gausi doo Gundulićev venac 37  
Beograd 11000 Tél. +381 11 3392731  
Fax +381 11 3392706 [info@gausi.com](mailto:info@gausi.com)  
[www.gausi.com](http://www.gausi.com)*