

NOXON

FREESBY SL



**AUTOMATIC TURNTABLE
FOR PALLET WRAPPING WITH STRETCH FILM**

*AUTOMATSKA MAŠINA ZA STREČOVANJE SA
OBRTNOM PLATFORMOM*

www.noxon.it

MACHINE / TIP MAŠINE	FREESBY SL 212	FREESBY SL 214
Carriage type / Tip nosača folije	Power pre-stretch motorized / Motorizovani pre-streč	2 variable pre-stretch motors / 2 varijabilna motora za podešavanje pre-streč funkcije
Film stretch / Podešavanje tenzije folije	Adjustable from panel / preko panela	
Pre-stretch / Pre-streč	250%	150÷400%
Power supply voltage / El. priključak	230 V 1 PH 50/60 Hz	
Installed power / Instalirana snaga	4 kW	4,3 kW
Carriage up-down speed / Brzina nosača folije gore-dole	1,5÷5,5 m/min	
Plate diameter / Prečnik obrtne ploče	Ø 1800 mm	
Max load weight / Maksimalna nosivost	1500 kg	
Table rotation speed / Brzina rotacione ploče	5÷15 RPM	
Variable rolls speed / Podesiva brzina valjaka	8÷11 or 12÷15 m/min	
Working height / Radna visina	400÷550 mm	
Max product dimension / Maksimalna dimenzija pakovanja	LxWxH 1200x1000x2400 mm (H 2800/3100 OPT)	
FILM FEATURES / CARACTÉRISTIQUES DU FILM / FILM FEATURES		
Reel dimensions / Dimenzije rolne folije	ØxH 300x500 mm	
Internal reel diameter / Unutrašnji prečnik hilzne	76 mm	
Film thickness / Debljina folije	17÷35 µm	

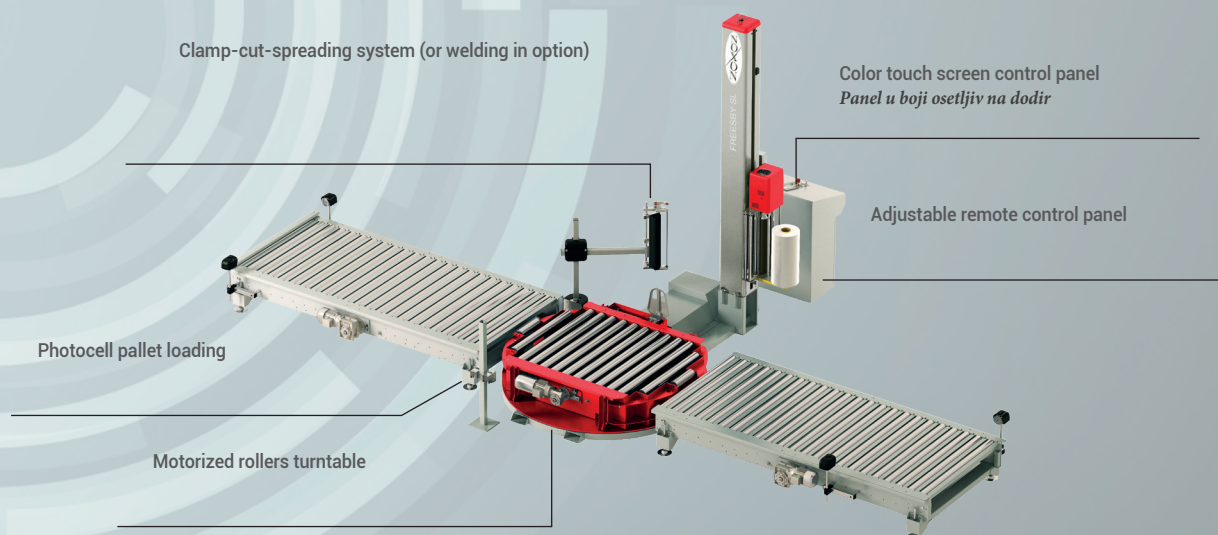

LAYOUT FREESBY SL

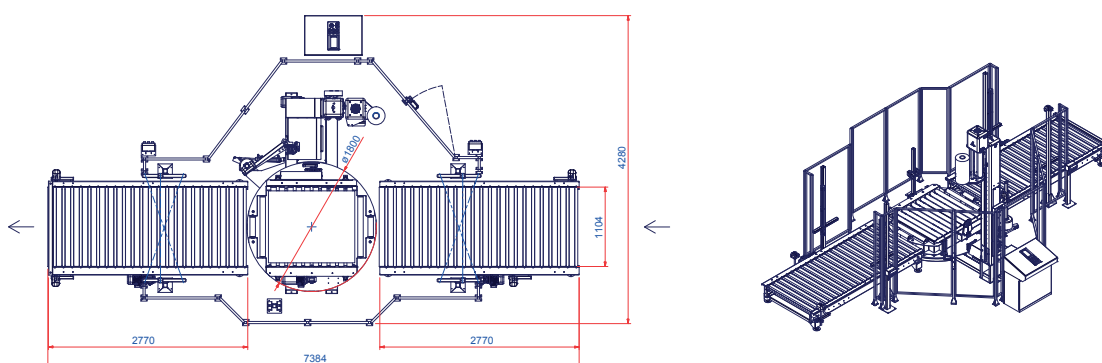

THE CONTENTS OF THESE CATALOGS HAVE BEEN VERIFIED BEFORE THE PRESS. NOXON RESERVES THE RIGHT TO MODIFY IN EVERY MOMENT THE TECHNICAL CHARACTERISTICS OF THE PRODUCTS AND ACCESSORIES ILLUSTRATED IN THE PRESENT DOCUMENT.

Gausi pak, Beograd, Gundulićev venac 37.
WWW.masinezapakovanje.com,
e-mail: info@masinezapakovanje.com

NOXON