

# AUTOMATSKA MAŠINA ZA HORIZONTALNO - ORBITALNO PAKOVANJE STREČ FOLIJOM

Wrappy<sup>®</sup>a



[www.masinezapakovanje.com](http://www.masinezapakovanje.com)



## Wrappy a4, a6, a9, a12

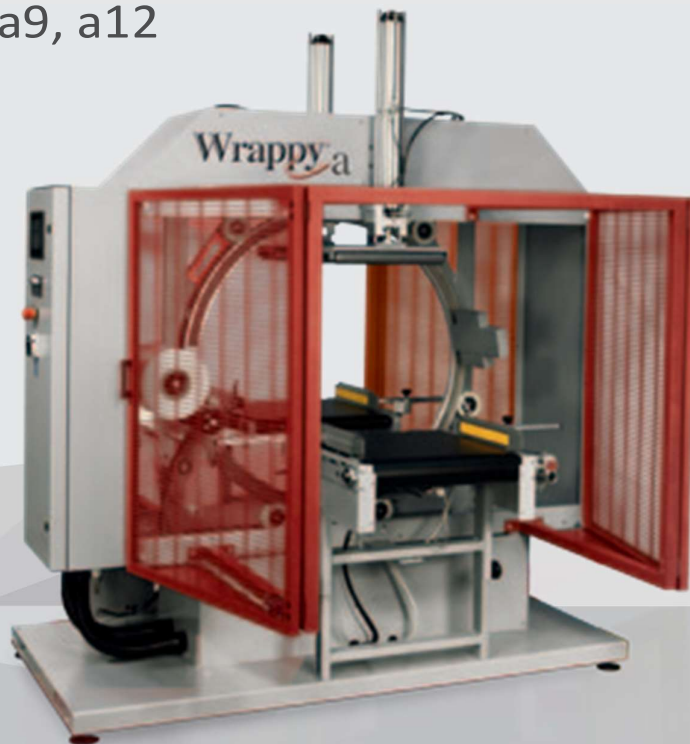

- Nož za odsecanje



- Ulazna traka podesiva po visini



- Ekran na dodir u boji

# Dimenzije Wrappy a4, a6, a9, a12

## Radne dimenzije

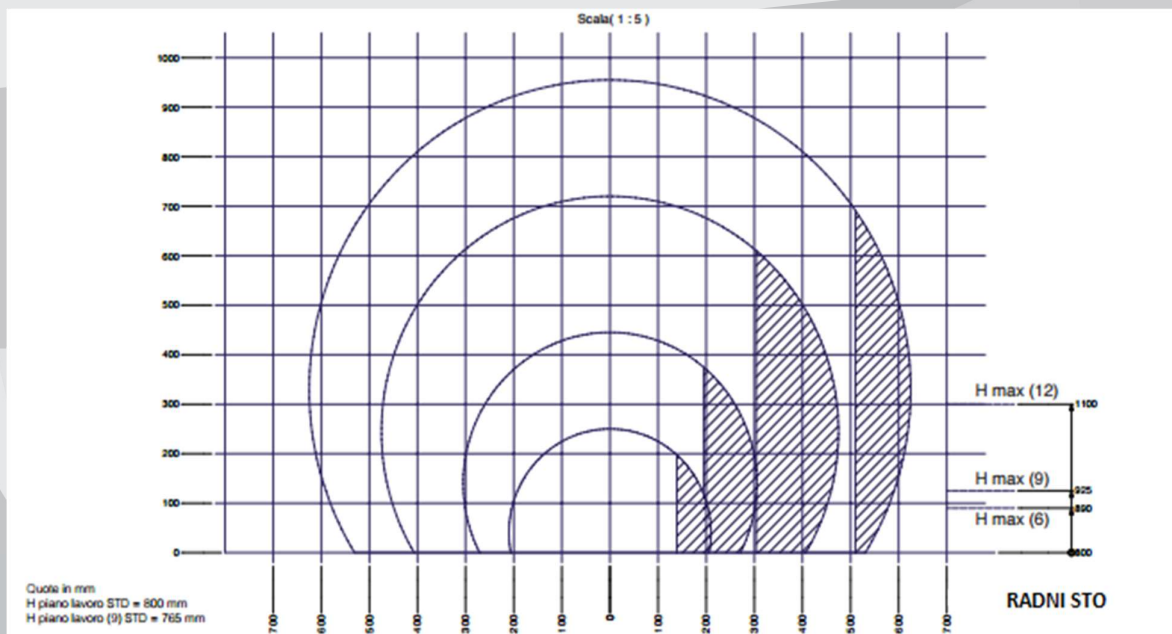

Hmin. Radni sto (standard 800mm)

Hmax. Visina radnog stola: (Wrappy A4: 800mm - Wrappy A6: 920mm - Wrappy A9: 950mm - Wrappy A12: 1100mm)

Minimalne dimenzije radnog stola: Wrappy A4: 50x50mm - Wrappy A6: 70x70 mm - Wrappy A9: 90x90mm - Wrappy A12: 150x150mm

### DIMENZIJE MAŠINE

MAŠINA	a4	a6	a9	a12
L mm	1985	1985	2160	2245
W mm	1258	1462	1920	2350
H mm	1350	1755	2182	2699
H' mm	800 (fissa)	800÷920	800÷950	800÷1100

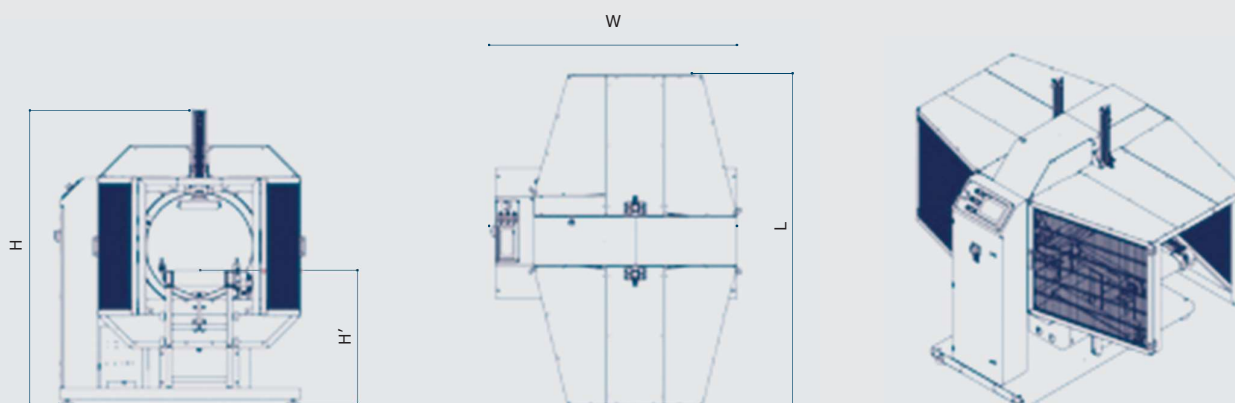

TEHNIČKE KARAKTERISTIKE

MAŠINA	a4	a6	a9		a12
Širina folije mm	125	125	125	250	125-250
Pogonski prenos preko kaiša	x	x	x	x	x
Maksimalni broj rotacija	160 rpm	120 rpm	75 rpm	60 rpm	58 rpm
Automatski ciklus omotavanja	x	x	x	x	x
Motorizovana ulazna I izlazna traka (mm)	600	600	600	600	850
Brzina kontrolisanja preko invertera (m/min.)	8÷17	6÷13	2÷8	4÷14	5÷13
Kontrola početka i kraja ciklusa pakovanja preko fotoćelije	x	x	x	x	x
Prenumatska presa na ulazu i izlazu	x	x	x	x	x
Mehaničko zatezanje folije	x	x	x	x	x
Napajanje	400V 3Ph+N 50/60 Hz	400V 3Ph+N 50/60 Hz	400V 3Ph+N 50/60 Hz	400V 3Ph+N 50/60 Hz	400V 3Ph+N 50/60 Hz
Instalirana snaga	0,9kW	1,1 kW	1,1 kW	1,1 kW	2 kW
Radni pritisak	6±1bar	6±1bar	6±1bar	6±1bar	6±1bar
Potrošnja vazduha (NI/cycle)	3,5	5	9,4	10,8	14,3
TEHNIČKE KARAKTERISTIKE FOLIJE					
Spoljašnji prečnik rolne (mm)	200	200	200	250	250
Prečnik hilzne (mm)	76	76	76	76	76



**Gausi doo**  
Gundulićev venac 37,  
11000 Beograd (Srbija)

Tel. +381 11 3392 706  
fax +381 11 3392 731  
info@gausi.com

[www.masinezapakovanje.com](http://www.masinezapakovanje.com)