

RUČNA MAŠINA ZA
HORIZONTALNO - ORBITALNO
PAKOVANJE STREČ FOLIJOM

Wrappy[®]m



Wrappy m4, m6, m9, m12



- Ulazna traka podesiva po visini



- Držać rolne



- Nož za odsecanje

Dimenzije Wrappy m4, m6, m9, m12

Radne dimenzije

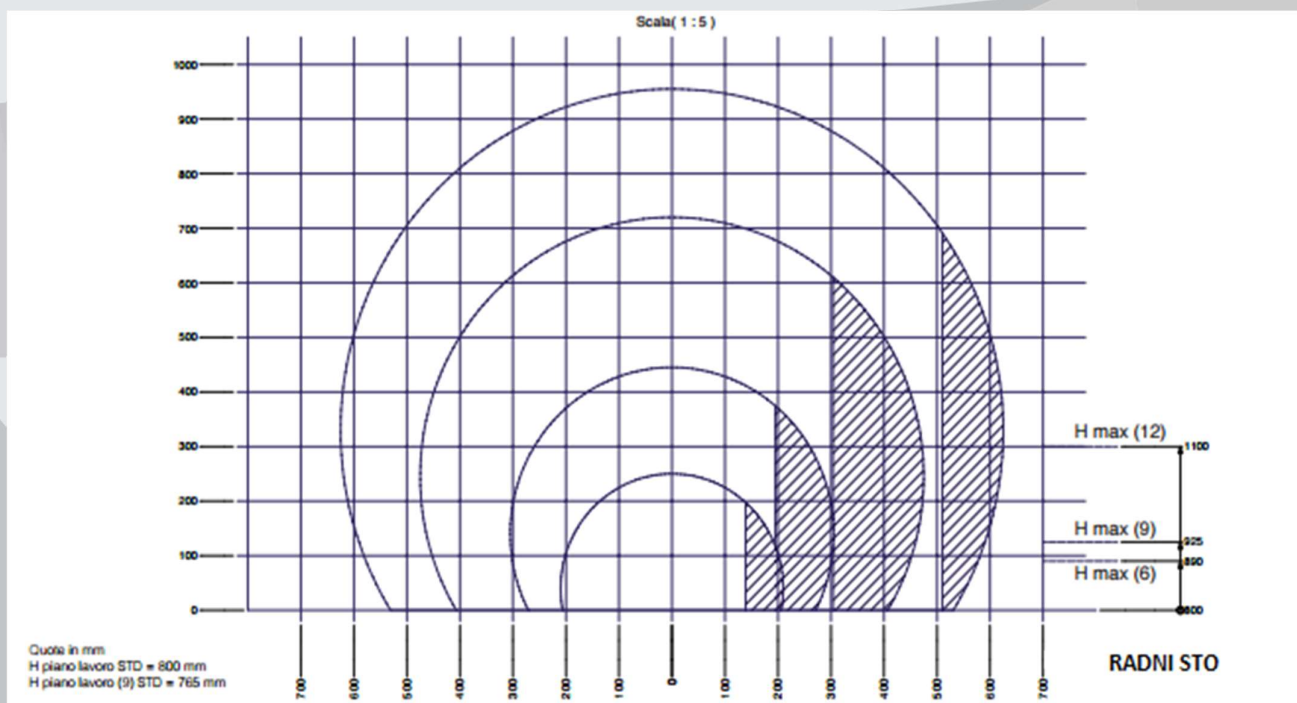

H min. Radni sto (standard 800mm) Wrappy M12 (standard 810mm)

H max. Visina radnog stola: (Wrappy M4: 800mm - Wrappy M6: 890mm - Wrappy M9: 925 mm - Wrappy M12: 1100mm)

Minimalne dimenzije radnog stola: Wrappy M4: 50x50mm - Wrappy M6: 70x70mm - Wrappy M9: 90x90mm - Wrappy M12: 150x150mm

DIMENZIJE MAŠINE				
MAŠINA	m4	m6	m9	m12
L mm	1010	1010	1400	2385
W mm	1234	1400	1930	2375
H mm	1340	1550	1850	2175
H' mm	800	800÷890	800÷950	800÷1100
X mm	350	450	715	910

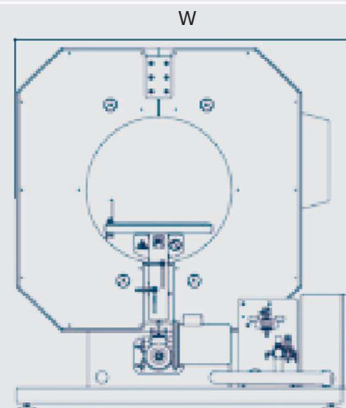
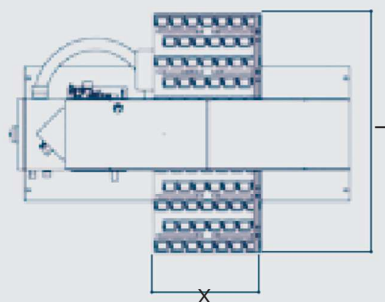
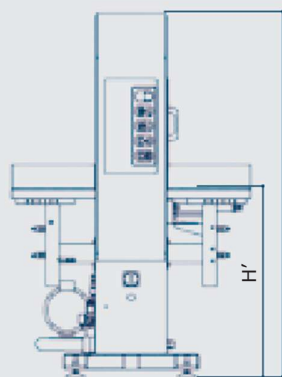

TEHNIČKE KARAKTERISTIKE

MAŠINA	m4	m6	m9		m12
Širina folije mm	125	125	125	250	125-250
Pogonski prenos preko kaiša	x	x	x	x	x
Maksimalni broj rotacija	150 rpm	120 rpm	75 rpm	60 rpm	58 rpm
Odsecanje folije pneumatskim pogonom	x	x	x	x	x
Mehaničko zatezanje folije	x	x	x	x	x
Napajanje	230V1Ph+ N50 60Hz	230V1Ph+ N50 60Hz	230V1Ph+ N50 60Hz	400V3Ph+ N50 60Hz	400V3Ph+ N50 60Hz
Instalirana snaga	0,55 kW	0,75 kW	0,75 kW	0,75 kW	1,5 kW
Radni pritisak	6±1bar	6±1bar	6±1bar	6±1bar	6±1bar
Potrošnja vazduha (NI/cycle)	1,8	1,8	1,8	3,2	3,2
TEHNIČKE KARAKTERISTIKE FOLIJE					
Spoljašnji prečnik rolne (mm)	200	200	200	250	250
Prečnik hilzne (mm)	76mm	76mm	76mm	76mm	76mm



Gausi doo
Gundulićev venac 37,
11000 Beograd (Srbija)

Tel. +381 11 3392 706
fax +381 11 3392 731
info@gausi.com

www.masinezapakovanje.com