

XTENSER Sth

Mašina sa frikcionim valjkom na nosaču folije i kontrolom zatezanja folije. Mašina radi sa bilo kojom vrstom streč filma. Nije potrebno napajanje, potpuno mehanički.

Machine with frictioned roller carriage and tension adjusting of the film. The machine run with any type of stretch film. Completely mechanical driving, it doesn't required any electric supply.



XTENSER

Mašina sa motorizovanim predistezanjem; Procenat prethodnog istezanja 100%. Mogu se prepoloviti troškovi pakovanja, idealan je za lagane i nestabilne proizvode. Baterija autonomije za pakovanje od 25 paleta po punjenju baterije.

Machine with motorized Power pre-stretch with stretch percentage of 100%. Half the costs of packaging and is ideal for light and unstable products. Battery powered with autonomy of 25 pallets per recharge.

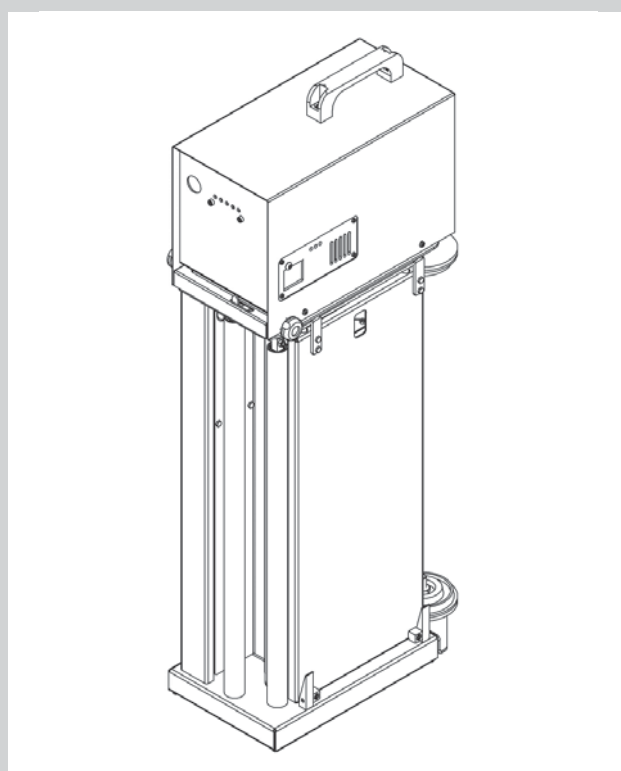

60 cm



Jedini sistem koji dozvoljava pakovanje na udaljenosti od samo 60 cm od palete.

The only system for wrapping with 60 cm around the pallet.



Bez napora za korisnika: zatezanje filma vrši isključivo Xtenser

No effort for the operator: the stretching of the film is totally to load of Xtenser.

Jednostavan, funkcionalan, odlični rezultati u malim prostorima

Simple, functional, great results in reduced spaces



CARATTERISTICHE TECNICHE / TECHNICAL FEATURES / TECHNISCHE EIGENSCHAFTEN

MACCHINA / MACHINE / MASCHINE	Xtenser Sth	Xtenser
Nosač folije Carriage Folienschlitten	Frikcioni valjak sa mehaničkom kočnicom Frictioned roller with mechanical brake	Pre-streč sa motorizovanim valjkom Power pre-stretch with motorized roller
Regolazione tensione film Adjusting tension film Einstellung der Folienspannung	manuale manual by operator manuelle Einstellung	manuale manual by operator manuelle Einstellung
Pre-stiro film / Film pre-stretch / Vorreckung Folie	-	100% (Opt. 200%)
Numero batterie / Number of batteries / Anzahi Akkus	-	2
Tipo di batteria / Type of batteries / Batterietyp	-	12VDC 9 Ah (C20)
Tensione di alimentazione / Power supply / Netz spannung	-	100-240 VAC - 50/60Hz
Potenza installata / Installed power / Installierte Leistung	-	0,07 kW
Velocità di rotazione e salita e discesa carrello Rotation speed and upward-downward carriage Drehgeschwindigkeit und Geschwindigkeit von Auf- und Abstieg	manuale manual by operator manuelle Einstellung	manuale manual by operator manuelle Einstellung
Numero di pallet per carica batteria (n.) Autonomy Pallet for single battery charger (n.) Anzahl gewickelte Paletten pro Aufladung (n.)	∞	25
Sollevamento carrello portabobina Spool carriage lifting Aufstieg und Abstieg Folienschlitten	manovella handle über kurbel	manovella handle über kurbel
Sistema anticaduta carrello Spool carriage anti-falling system Fallschutz- und Einklemmschutzvorrichtung am Folienschlitten	STD	STD
Dispositivo di frenatura su una ruota posteriore Braking device on one rear wheel Bremsssystem auf hinteres Rad	STD	STD
CARATTERISTICHE FILM / FILM FEATURES / MERKMALE DER FOLIEN		
Diametro esterno max. / Max. external diameter / Max. Aussendurchmesser	180	145
Diametro interno / Internal diameter / Innendurchmesser	50-76	50-76
Spessore film / Film thickness / Folienstärke	17-35 µm	17-35 µm
Altezza bobina / Spool height / Rollenbreite	500 mm	500 mm
CONTROLLO / CONTROL / STEUERUNG		
Pulsante d'emergenza / Emergency button / Not-Aus Knopf	-	STD

DIMENSIONI MACCHINA / MACHINE DIMENSION / MBESSUNGEN DER MASCHINE

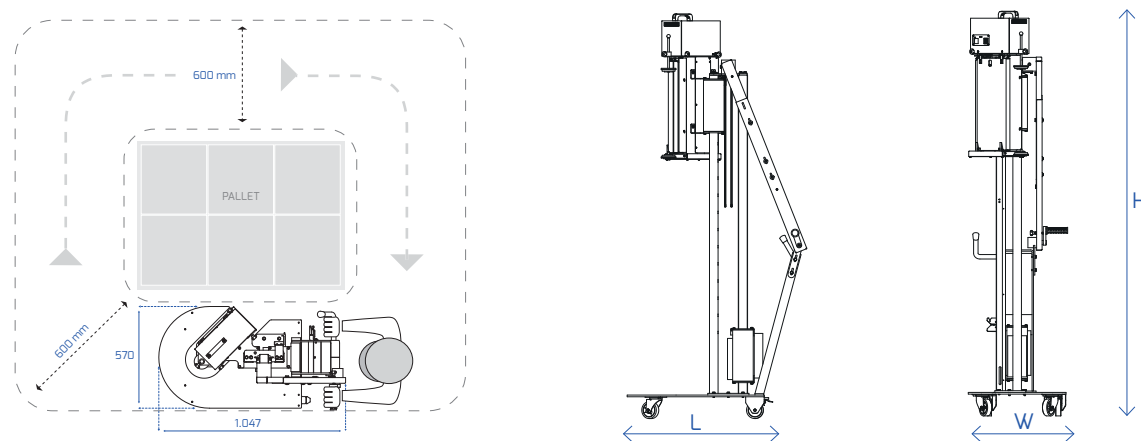

Altezza massima prodotto Product maximum useful height Produkt Max. Wickelhöhe - (mm)	2000 - (Opt. 2400)	2000 - (Opt. 2400)
Xtenser Sth 2.0 LxWxH (mm)	1047 x 570 x 2277	-
Xtenser Sth 2.4 LxWxH (mm)	1047 x 570 x 2639	-
Xtenser 2.0 LxWxH (mm)	-	1047 x 570 x 2359
Xtenser 2.4 LxWxH (mm)	-	1047 x 570 x 2721

I CONTENUTI DI QUESTO CATALOGO SONO STATI VERIFICATI AL MOMENTO DELLA STAMPA. ROBOPAC SI RISERVA IL DIRITTO DI MODIFICARE IN OGNI MOMENTO LE CARATTERISTICHE TECNICHE DEI PRODOTTI E DEGLI ACCESSORI ILLUSTRATI NEL PRESENTE DOCUMENTO.
THE CONTENTS OF THESE CATALOGS HAVE BEEN VERIFIED BEFORE THE PRESS. ROBOPAC RESERVES THE RIGHT TO MODIFY IN EVERY MOMENT THE TECHNICAL CHARACTERISTICS OF THE PRODUCTS AND THE ILLUSTRATED ACCESSORIES IN THE PRESENT DOCUMENT.
DIE INHALTE VON DIESEM KATALOG Ä. WURDE DEN AUGENBLICK DES DRUCKES GEPRÜFT. ROBOPAC VORBEHALTEN DAS RECHT, ANDERN, DIE EIGENSCHAFTEN SIND TECHNIKEN ENIGE IN DEN ANWESENDEN URKUNDEN ILLUSTRIRT BEWERKE.