

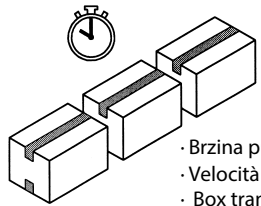

F1000

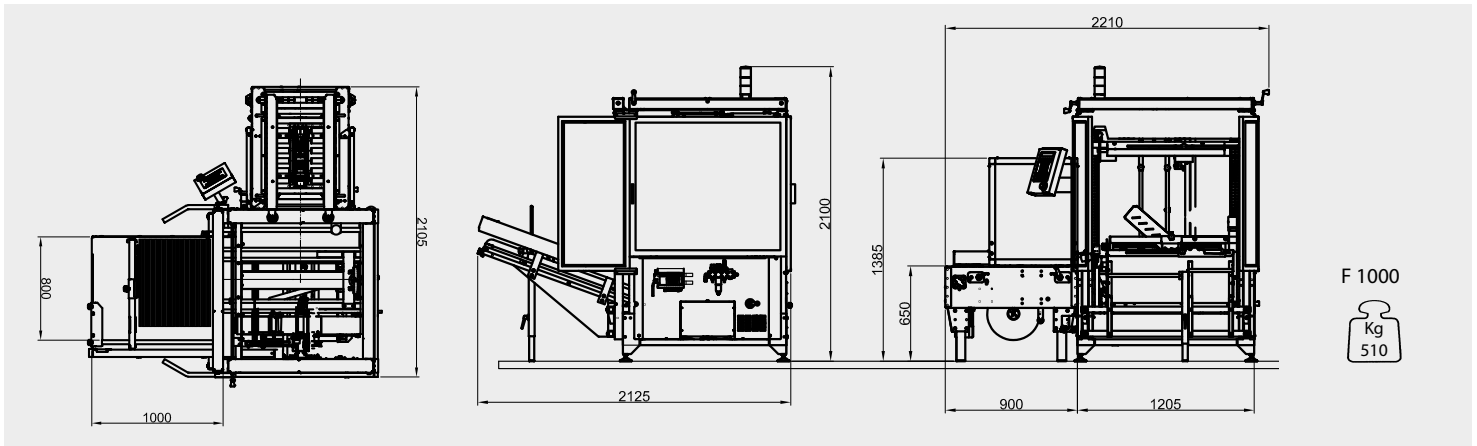

- AUTOMATSKO FORMIRANJE KUTIJA
- FORMATORE AUTOMATICO DI SCATOLE
- FORMEUSE AUTOMATIQUE DE CARTONS



· Produktivnost : 840 kutija/sat  
 · Produzione media: 840 scatole/ora  
 · Average production: 840 boxes/hour

· Zahtevani pritisak vazduha  
 · Alimentazione pneumatica  
 · Pneumatic power supply

· Potrošnja vazduha po ciklusu  
 · Consumo aria per ciclo scatola  
 · Air consumption cycle box

· Brzina prenosa kutija: ~22 m/min  
 · Velocità di trasferimento scatola: ~22 mt/min  
 · Box transfer speed: ~22 mt/min

6 bar

22 nl

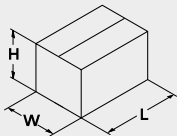

F 1000

	MIN	MAX
L	180 mm	400 mm
W	100 mm	400 mm
H	100 mm	500 mm

· OPCIONO:

· Točkići za minimalnu radnu visinu 750mm  
 · Motorizovani magacin kapaciteta 270 kutija

· OPTIONALS:

· Ruote con freno

· Magazzino motorizzato con capacità scatole fino a 270 sc.modello CAR 2001

OPTIONALS:

· Caster wheels for min working table height 750 mm

· CAR 2001 Motorised box loader with capacity of 270 boxes



· El.priključak: Trofazni/Monofazni  
 · Alimentazione: Trifase/Monofase  
 · Power supply: Three-phase/Single-phase

· Instalಿಸana snaga: 0,40 Kw  
 · Potenza installata: 0,40 Kw  
 · Installed power: 0,40 Kw

· El. zaštita: IP54  
 · Protezione elettrica: IP54  
 · Electrical protection: IP54

· Kapacitet magacina za ulaganje 110 kutija  
 · Capacità magazzino: 110 scatole  
 · Box loader unit capacity: 110 boxes

· Vakuem sistem Venturi 25m<sup>3</sup>/h 700mm HG  
 · Sistema vuoto Venturi: 25m<sup>3</sup>/h 700mm HG  
 · Venturi vacuum unit: 25m<sup>3</sup>/h 700mm HG

🇷🇸 Lepilica kutija GEM52

🇮🇹 Nastratrice GEM B52 per chiusura falde inferiori scatola

🇬🇧 Bottom case sealer GEM B52 model to bottom flaps closing



🇷🇸 PLC sa ekranom osetljivim na dodir  
 🇮🇹 PLC con pannello touch screen  
 🇬🇧 Control panel with Siemens / Omron / Schneider / Allen-Bradley PLC

Distributed by

Gausi doo Gundulićev venac 37,  
 Beograd  
 www.gausi.com  
 tel:011/3392731  
 e:mail:info@gausi.com

