

BP800AR 350P/802AR 350P

Monoblok automatska mašina za grupno pakovanje sa ulaznom trakom pod 90°



Nova serija poluautomatskih i automatskih mašina za pakovanje TS PET folijom serije BP su izuzetno raznovrsne: mogu da spakuju razne proizvode, kao što su staklene i PET boce, limenke, kutije, tegle, kartone različitih veličina u širokom opsegu načina grupisanja proizvoda u paket. Mogu se koristiti u nekoliko industrijskih segmenata, kao što su pića, hrana, hemikalije, vino i alkoholna pića, kozmetika, deterdženti, drvo, tekstil, grafika itd.

Serija BP omogućava SMIPACK-u da zadovolji širok spektar zahteva kupaca i da obezbedi veoma dobar odnos kvaliteta i cene.

KARAKTERISTIKE I PREDNOSTI

- Automatska mašina za pakovanje LDPE termoskupljajućom folijom sa ulaznom trakom 90°
- Bez automatskog slaganja paketa
- Tunel sa jednim (BP800AR) ili dva ventilatora (802AR)
- Ulazna traka po uglom 90° sa kontrolom brzine preko Inveretera
- Proizvodi se mogu ulagati sa verijantom dodavanja sa leve ili desne strane
- Fotočelija detektuje prisustvo proizvoda
- Motorizovani gurač paketa se kontroliše inverterom i encoderom
- Motorizovano odmotavanje gornje rolne folije kontroliše inverter
- Motorizovano odmotavanje donje rolne folije
- Uključeno: nogice-stope za pričvršćivanje mašine, letva za poravnavanje proizvoda, ventilator na izlazu iz tunela
- Mašina se može postaviti u automatski ili poluautomatski režim rada
- Monoblok ram, spojena sekcija za varenje i tunel
- Pneumatska letva za varenje opremljena sigurnosnim senzorom
- Folija se seče hladnim nožem pneumatski
- Letva za varenje opremljena sigurnosnim senzorom
- Valjci postavljeni za donju i gornju rolnu folije za lakše odmotavanje folije
- Metrička podela na sistemu za centriranje filma
- FLXMOD®, elektronski sistem kontrole opremljen sa:
 - 7" touchscreen kolor displej
 - Plc
 - Inverter sa integrisanim encoderom
 - in/out kontrolni modul
- Mogućnost memorisanja do 50 programa rada
- Protok vazduha u tunelu podesiv pomoću nezavisnih deflektora – usmerivača vazduha
- Transportna traka u tunelu opremljena valjcima od staklenih vlakana – fiber glass, otpornih na toplotu (SMI patent) koji osigurava:
 - ukrućenost transportne trake omogućava stabilan prolaz pakovanje kroz tunel, za kompaktan izgled i dobro skupljenu foliju oko paketa
 - transportna traka može da nosi pakete do 30 kg
 - valjci na transportnoj traci ne mogu da zardjaju, kao što se dešava kod tradicionalnih metalnih transportnih traka
 - održavanje je jednostavno i jeftino zahvaljujući mogućnosti promene samo jednog oštećenog valjka
- Tunel ima automatsko isključivanje
- Niska potrošnja energije
- 4.0 industry uskladjenost
- Uskladjenost sa propisima CE standard

Princip rada

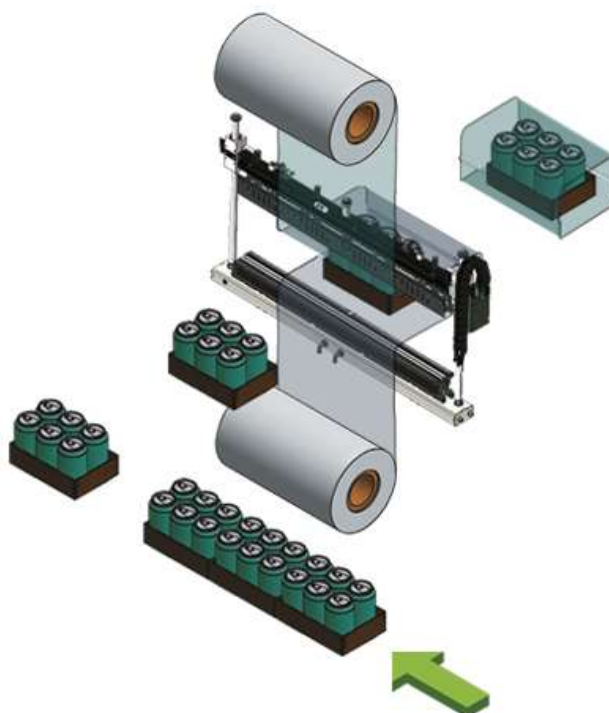

Tehničke karakteristike:

	800 AR 350P	802 AR 350P
Power supply	220 - 240 / 380 - 415 V	220 - 240 / 380 - 415 V
	3PH + PE / 3PH + N + PE	3PH + PE / 3PH + N + PE
	50/60 Hz	50/60 Hz
Installed power	17400 W	26900 W
Air pressure	6 Bar	6 Bar
Required air	11,5 NI/p*	11,5 NI/p*
Maximum output up to	15 ppm**	20 ppm**
Product maximum height	380 mm	380 mm
Sealing bar	760 mm	760 mm
Maximum size of film reel	750 x Ø 350 mm	750 x Ø 350 mm
Working board height	945 - 1105 mm	945 - 1105 mm
Machine size	2845 x 2500 mm	3675 x 2500 mm
	h 2105 - 2265 mm	h 2105 - 2265 mm
Machine net weight	770 Kg	950 Kg
Advised film: LDPE	20 - 100 µ	20 - 100 µ

(*) Normalna potrošnja litara po paketu.

(**) Paketa po minutu. Brzina i broj paketa može se menjati u zavisnosti od veličine paketa, načina slaganja paketa i vrste folija koja se koristi.

Veličina paketa koji mogu biti spakovani

* **P** označava razmak koji proizvodi moraju imati na 90 ° ulaznom transporteru; da bi se postiglo najbolje moguće skupljanje folije, koristite formulu naznačenu na tabeli da biste izračunali P (u zavisnosti od dužine X formata)..

Maksimalna težina paketa: 30 kg

a) Standardni mod

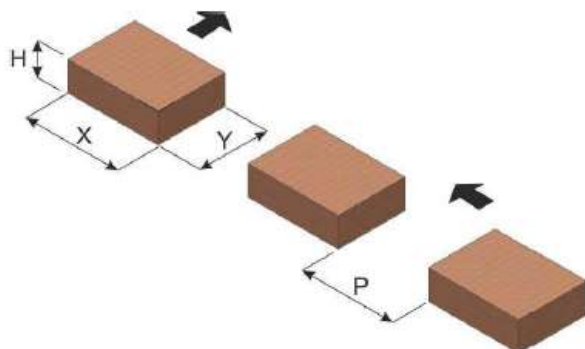

X min	40 mm
X max	560 mm
Y min	40 mm
Y max	350 mm
H min	40 mm
H max	380 mm
P*	370 mm - (X/2)

b) Grupisanje proizvoda na guraču

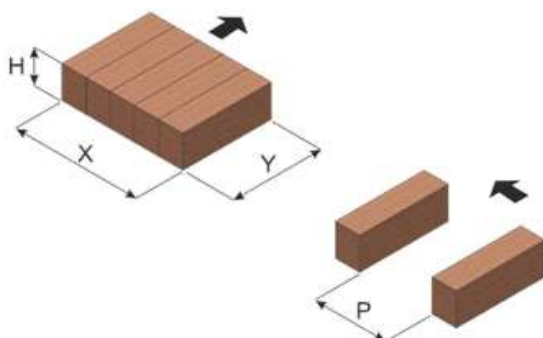

X min	80 mm
X max	560 mm
Y min	40 mm
Y max	350 mm
H min	40 mm
H max	380 mm
P*	370 mm - (X/2)

c) Grupisanje proizvoda na guraču sa više kombinacija

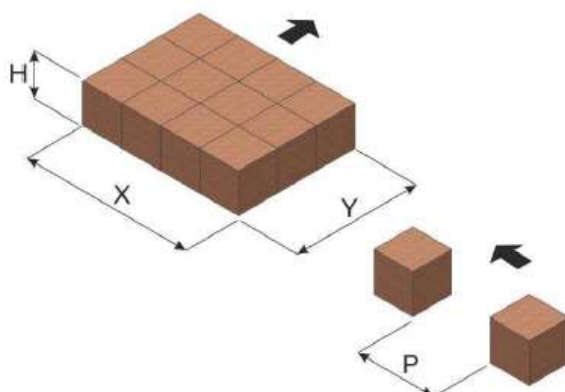

X min	80 mm
X max	560 mm
Y min	40 mm
Y max	400 mm
H min	40 mm
H max	380 mm
P*	370 mm - (X/2)

Karakteristike folije i dimenzije rolne folije

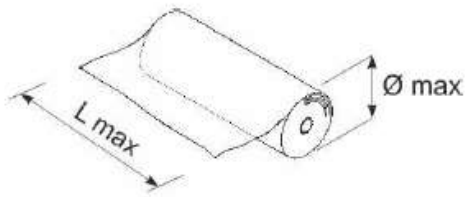
Type of film	LDPE	
Thickness of film	from 20 to 100 µm	
Ø max upper and lower reel	350 mm	
L max reel	750 mm	

Odredjivanje širine folije

Za odredjivanje širine rolne filma koristite formulu ispod:

$$\text{MINIMALNA ŠIRINA FOLIJE} = \text{ŠIRINA X} + \text{VISINA H}$$

Ako želite da bočni deo proizvoda bude zatvoreniji filmom (smanjujući merenje H1) povećajte širinu rolne folije

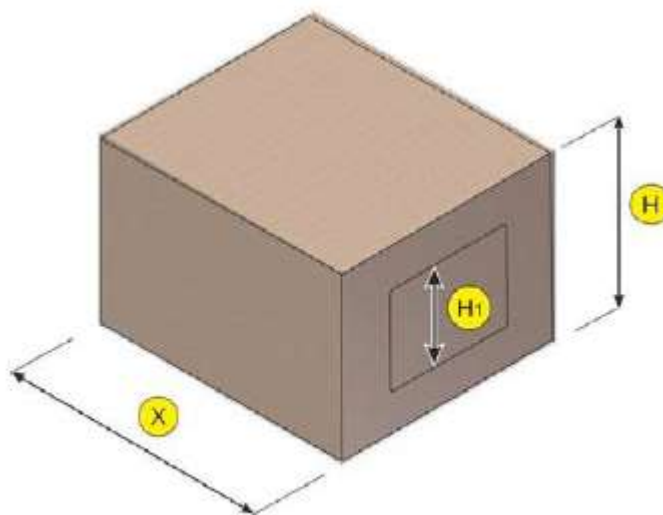

Odredjivanje brzine pakovanja (u zavisnosti od dimenzija proizvoda)

Model BP800AR 350P









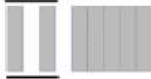

PACKS/MINUTE (depending on X and Y)			WIDTH Y (mm)						
			50	100	150	200	250	300	350
LENGTH X (mm)	H from 40 to 250	100	14-16	12-14	12-14	10-12	10-12	8-10	8-10
		200	14-16	12-14	10-12	10-12	10-12	8-10	8-10
		300	12-14	12-14	10-12	10-12	8-10	8-10	8-10
		400	12-14	12-14	10-12	8-10	8-10	8-10	8-10
		500	12-14	10-12	8-10	8-10	8-10	6-8	6-8
		560	10-12	10-12	8-10	8-10	8-10	6-8	6-8
	H from 250 to 380	100	14-16	12-14	12-14	10-12	10-12	8-10	8-10
		200	14-16	12-14	10-12	10-12	8-10	8-10	8-10
		300	12-14	12-14	10-12	10-12	8-10	8-10	8-10
		400	12-14	12-14	10-12	8-10	8-10	8-10	8-10
		500	12-14	10-12	8-10	8-10	8-10	6-8	6-8
		560	10-12	10-12	8-10	8-10	8-10	6-8	6-8

Model 802AR 350P

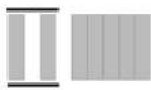









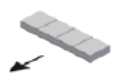

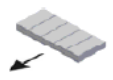

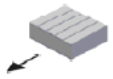

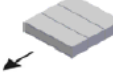

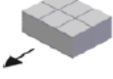

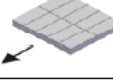
PACKS/MINUTE (depending on X and Y)			WIDTH Y (mm)						
			50	100	150	200	250	300	350
LENGTH X (mm)	H from 40 to 250	100	20-22	20-22	18-20	16-18	16-18	14-16	14-16
		200	18-20	18-20	18-20	16-18	16-18	14-16	14-16
		300	18-20	18-20	18-20	16-18	14-16	14-16	14-16
		400	18-20	16-18	16-18	14-16	14-16	14-16	12-14
		500	16-18	16-18	16-18	14-16	14-16	12-14	12-14
		560	16-18	16-18	14-16	14-16	12-14	12-14	12-14
	H from 250 to 380	100	20-22	20-22	18-20	16-18	16-18	14-16	14-16
		200	20-22	18-20	18-20	16-18	14-16	14-16	14-16
		300	18-20	18-20	18-20	16-18	14-16	14-16	14-16
		400	18-20	16-18	16-18	14-16	14-16	14-16	12-14
		500	16-18	16-18	16-18	14-16	14-16	12-14	12-14
		560	16-18	16-18	14-16	14-16	12-14	12-14	12-14

Teorijska produktivnost mašine

BP800AR 350P

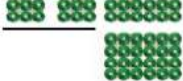
	Format	Dimenzija pojedinačnog proizvoda	Dolazna traka 1 red	PPM	Opis proizvoda
1		120x140 mm h: 150 mm		7	BOX
	4 x 1	480x140 h: 150			
2		100x230 mm h: 50 mm		6	
	5 x 1	500x230 h: 50			
3		50x230 mm h: 95 mm		8	
	5 x 1	250x230 h: 95			
4		198x132 mm h: 230 mm		10	PET - bottles/cans (already packed)
	2 x 1	396x132 h: 230			
5		265x198 mm h: 120 mm		12	on tray (with several products inside)
	tray 4 x 3	265x298 h: 120			
6		400x265 mm h: 120 mm		10	
	tray 6 x 4	400x265 h: 120			

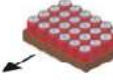
Model BP802AR 350P

	Format	Dimenzija pojedinačnog proizvoda	Dolazna traka 1 red	PPM	Opis proizvoda
1		120x140 mm h: 150 mm		13	BOX
	4 x 1	480x140 h: 150			
2		100x230 mm h: 50 mm		11	
	5 x 1	500x230 h: 50			
3		50x230 mm h: 95 mm		13	
	5 x 1	250x230 h: 95			
4		500x130 mm h: 100 mm		5	
	1 x 3	500x390 h: 100			
5		120x140 mm h: 150 mm		7	
	3 x 2	360x280 h: 150			
6		100x230 mm h: 50 mm		5	
	5 x 2	500x400 h: 50			
7		50x50 mm h: 60 mm		6	
	4 x 3	200x150 h: 60			
8		198x132 mm h: 230 mm		15	PET - bottles/cans (already packed)
	2 x 1	396x132 h: 230			
9		198x132 mm h: 230 mm		8	
	2 x 2	396x264 h: 230			
10		265x198 mm h: 120 mm		18	on tray (with several products inside)
	tray 4 x 3	265x298 h: 120			
11		400x265 mm h: 120 mm		16	
	tray 6 x 4	400x265 h: 120			