

# NOXON

## EKKO T3

*POLUAUTOMATSKA MAŠINA ZA STREČOVANJE PALETA SA OBTNOM PLOČOM ZA ULAZ PALETARA*  
SEMI-AUTOMATIC TURNTABLE, FOR PALLET WRAPPING WITH STRETCH FILM TRANSPALET



**Simple, sturdy  
and reliable**

***Jednostavna,  
robusna i  
poudana***

## SEMI-AUTOMATIC TURNTABLE, FOR PALLET WRAPPING WITH STRETCH FILM TRANSPALET



**“X3” CONTROL/  
„X3“-Kontrol panel  
Korisnički  
interfejs sa  
grafičkim  
tasterima sa  
membranom**

**Operator Interface  
with graphic membrane  
keypad and  
2.23” OLED DISPLAY/**

### “X3” SPECIFICATIONS CONTROL/ PREGLED KOMANDI

**Brzina nosača folije gore-dole**

Upward-downward carriage speed

**Tenzija omotavanja na dnu i vrhu palete**

Top and bottom reinforcement wraps

**Tenzija zategnuti folije / Film tension**

**Brzina okretanja obrtne ploče/ Table rotation speed**

**Zaustavljanje nosača folije na ergonomku visinu**

Ergonomic carriage stop at the end of the cycle

**Ciklus gore-dole / Upward-downward cycle**

**Ciklus samo gore / Only upward cycle**

**Ciklus omotavanja na vrhu / Topsheet cycle**

**Ručni ciklus / Manual cycle**

**Ciklus samoučenja / Self learning cycle**

**Fotoćelija za visinu palete i odloženi start**

Altimeter and photocell delay

**Učitavanje 6 različitih programa/ 6 recordable programs**

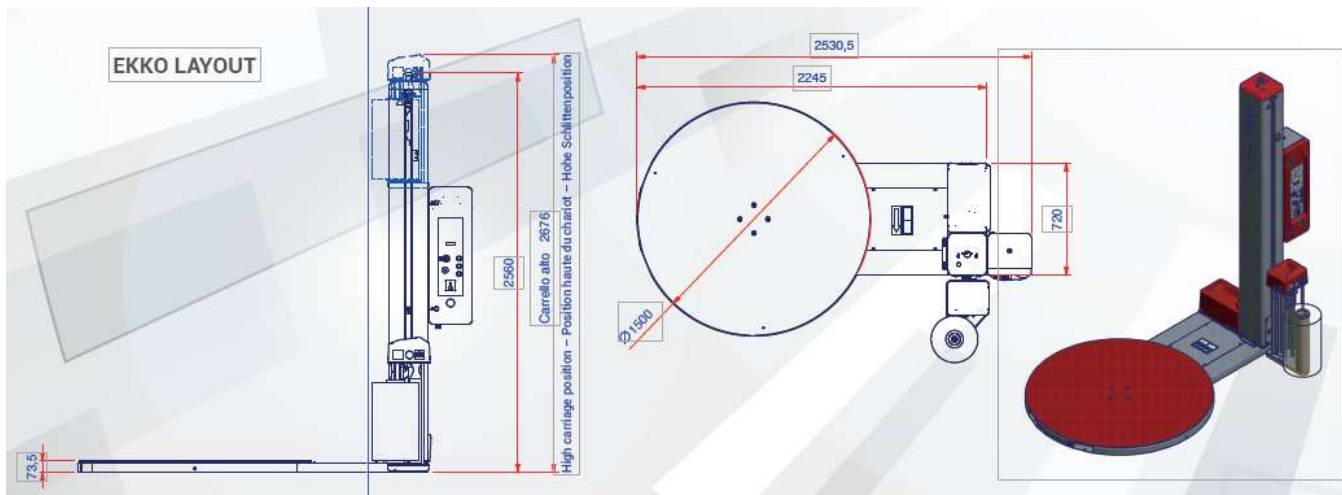

CARRIAGES / NOSAČ FOLIJE

**EKKO T3 302**

**NOSAČ FOLIJE SA MEHANIČKOM KOČNICOM ZA PODEŠAVAJE ZATEGNETOSTI FOLIJE.**

*Podešavanje zategnutosti folije kojom se obavija paleta. Nosač je opremljen jednostavnim mehanizmom koji omogućava brzo uključivanje/isključivanje ove funkcije*  
**FILM CARRIAGE WITH MANUALLY ADJUSTABLE MECHANICAL BRAKE.**

*The "Film's Tension" adjustment allows to set the tension with which the film is applied to the product. The carriage is equipped with a quick engagement and disengagement device to facilitate the hooking of the film on the product.*



**Ekko T3 310**

*Nosač folije sa elektromagnetnom kočnicom na povratnom valjku. Tenzija zategnutosti folije se podešava preko panela. Kočnica se lako aktivira nakon pokretanja ciklusa.*

*Film carriage with electromagnetic brake on return roller. Stretch tension adjustable from control panel. Brake coupling after cycle start for easy film hooking to pallet base.*



**EKKO T3 312**

*Nosač folije opremljen fiksnim pre-sreč sistemom 250%. Sila zategnutosti kontrolisana preko merne ćelije i podešava se preko panela*

*The carriage is fitted with a pre-stretching system fixed at 250%. Force to the load controlled by load cell and adjustable from control panel.*

**TECHNICAL FEATURES / TEHNIČKE KARAKTERISTIKE**

MACHINE / MODEL	EKKO T3 302	EKKO T3 310	EKKO T 3 312
Tip nosača folije / Carriage type	Mehanička kočnica Mechanical brake/	Elektromagnetna kočnica Electromagnetic power brake/	Motorizovani pre-streč Power pre-stretch motorized /
Zatezanje folije / Film stretch	Ručno podešavanje Manual adjustment	Podešavanje preko panela Adjustable from panel	Potenciometar Potentiometer
Pre-streč / Pre-stretch	No	No	250%
Napajanje / Power supply voltage	(VAC) 230V 1 PH(±10%) 50/60 Hz		
Intalisana snaga / Installed power	1,2 kW	1,5 kW	1,9 kW
Brzina nosača folije / Carriage up-down speed	1,4÷4 m/min		
Brzina rotiranja obrtne ploče / Table rotation speed	5÷12 rpm	5÷12 rpm	5÷12 rpm
Prečnik obrtne ploče / Plate diameter	Ø 1500 STD (59") - Ø 1650 OPT (65")		
Nosivost obrtne ploče / Plate capacity	1500kg STD		
Fazno zaustavljanje / Phase stopping point	STD		
Progresivan start / Progressive start-up	STD		
Fotoćelija za odloženi start / Photocell delay /	STD		
Fotoćelija za detekciju visine / Height detection	STD		
Omogućen prilaz za premeštanje viljuškaram Front and rear forklift capability	STD		
<b>PRODUCT CHARACTERISTICS / KARAKTERISTIKE PAKOVANJA</b>			
Minimalne dimenzije pakovanja / Min product dimensions/	LxWxH 500 x 500 x 500 (mm) / 20 x 20 x 20 (")		
Maksimalne dimenzije pakovanja / Max product dimensions	LxWxH 800x1200x2200 (mm) STD 1000x1200x2400 (mm) OPT		
<b>FILM FEATURES / KARAKTERISTIKE FOLIJE</b>			
Max. spoljni prečnik / Max. External diameter	300 mm		
Širina folije / Reel height	500 mm		
Debljina folije / Film thickness	17÷35 µm		
Unutrašnji prečnik hilzne / Internal diameter	76 mm		
Max. težina rolne / Max spool weight	20 kg		

## EKKO T3

### **POLUAUTOMATSKA MAŠINA ZA STREČOVANJE SA OBRTNOM PLOČOM**

**Ekko predstavlja prvu Noxonovu investiciju u vertikalne mašine za strečovanje sa obrtnom pločom za slobodan ulaz paletnog viljuškara.**

**Ekko je dizajniran kombinovanjem najboljih tehnologija za pakovanja sa inovativnim i osnovnim dizajnom, dok istovremeno ispunjava najstrože međunarodne bezbednosne standarde. Posebna pažnja je posvećena podešavanju faza ubrzanja i usporavanja obrtne ploče kako bi se osigurala maksimalna sigurnost pri rukovanju nestabilnim teretima. Ove karakteristike, zajedno sa novom linijom nosača folija i „X3“ kontrolnim panelom, čine EKKO seriju jednostavnim, robusnim i pouzdanim mašinama.**

### **SEMI-AUTOMATIC TURNTABLE FOR PALLET WRAPPING WITH STRETCH FILM TRANSPALET**

Ekko represents Noxon's first investment in vertical turntable wrappers. Ekko has been designed by combining the best packaging technologies with an innovative and essential design, while also meeting the strictest international safety standards. Particular attention has been paid to adjusting the acceleration and deceleration phases of the turntable to ensure maximum safety when handling unstable loads. These features, together with the new carriage line and the "X3" control, make the EKKO simple, robust and reliable.



Gausi pak  
Beograd, Gundulićev venac 37  
[Tel: +381 11 3392731, 3392720](tel:+381113392731)  
e-mail: [info@gausi.com](mailto:info@gausi.com)  
[WWW.Masinezapakovanje.com](http://WWW.Masinezapakovanje.com)